



FCC Gliding 2022

Safety briefing



The person you are looking at is responsible for your safety!



The organizing team is kindly asking you to fly safely.

Look inside the turn before you turn.

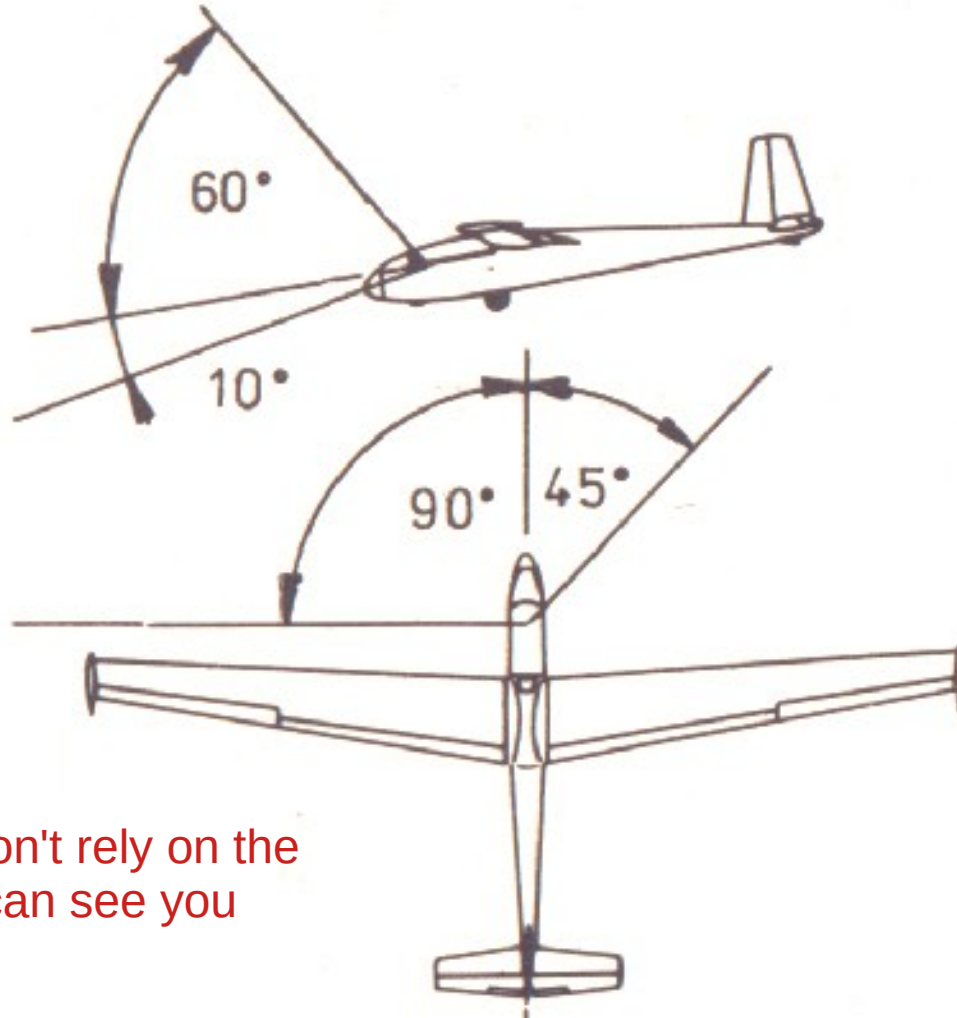

Everybody has blind spots. Don't rely on the fact that the pilot behind you can see you

Safe circling is always before optimal circling.

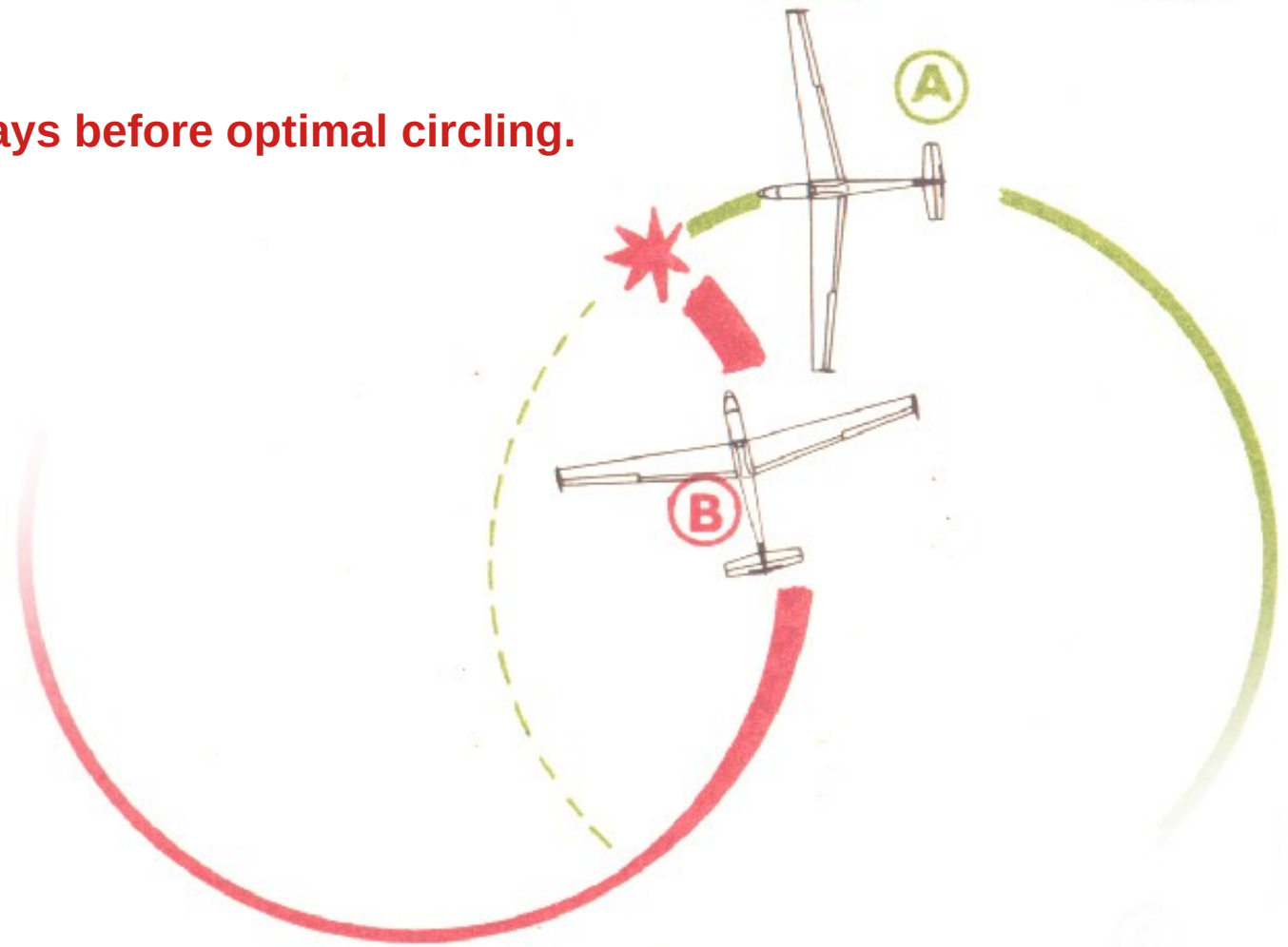

In the same height keep the same circle

If you are not happy with climbing, DON'T undercut others in thermals.

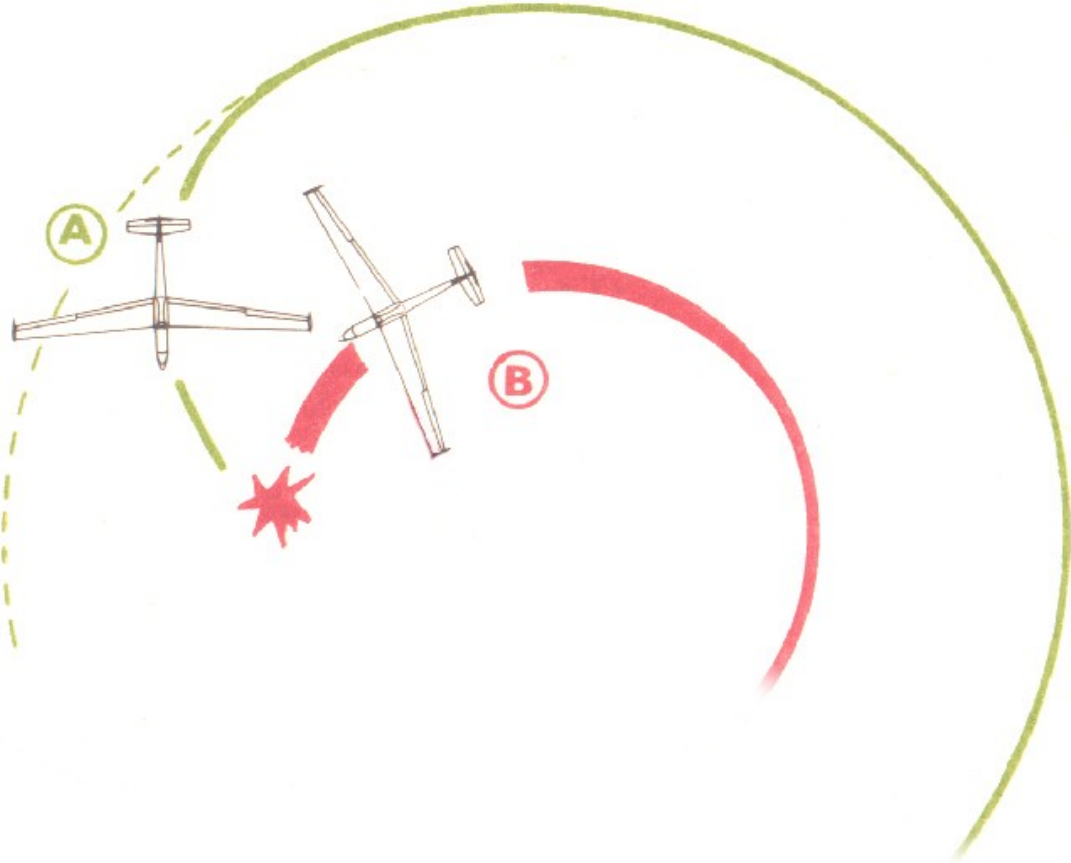

**When entering circling, or you are in the circling already,
Always behave as that other pilots YOU have in sight**

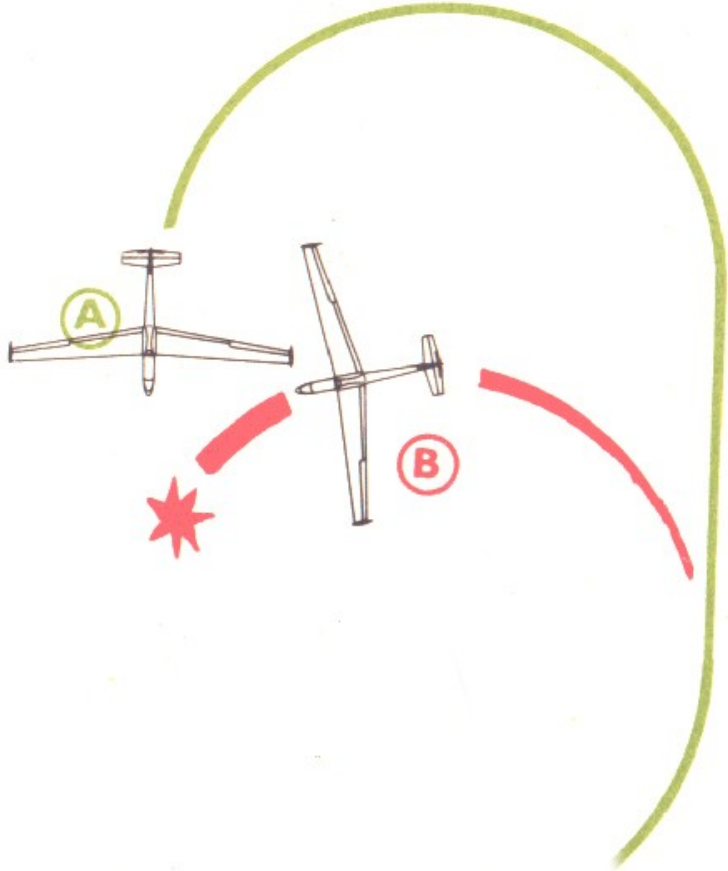

Watch outside!

Flarm is not Airbag.
It will not save you.
It will ONLY warn you.



The organizing team is kindly asking you to fly safely.

Flarm is mandatory

Tomorrow (27th April 2022) before the flight we will check presence of the flarm in all gliders

Outlandings

Please send text message with your GPS position in case of outlandig to:

+421 908 706 340

We need to know that you are safe!

Safety briefing Landing procedures

..... Airport Boundary

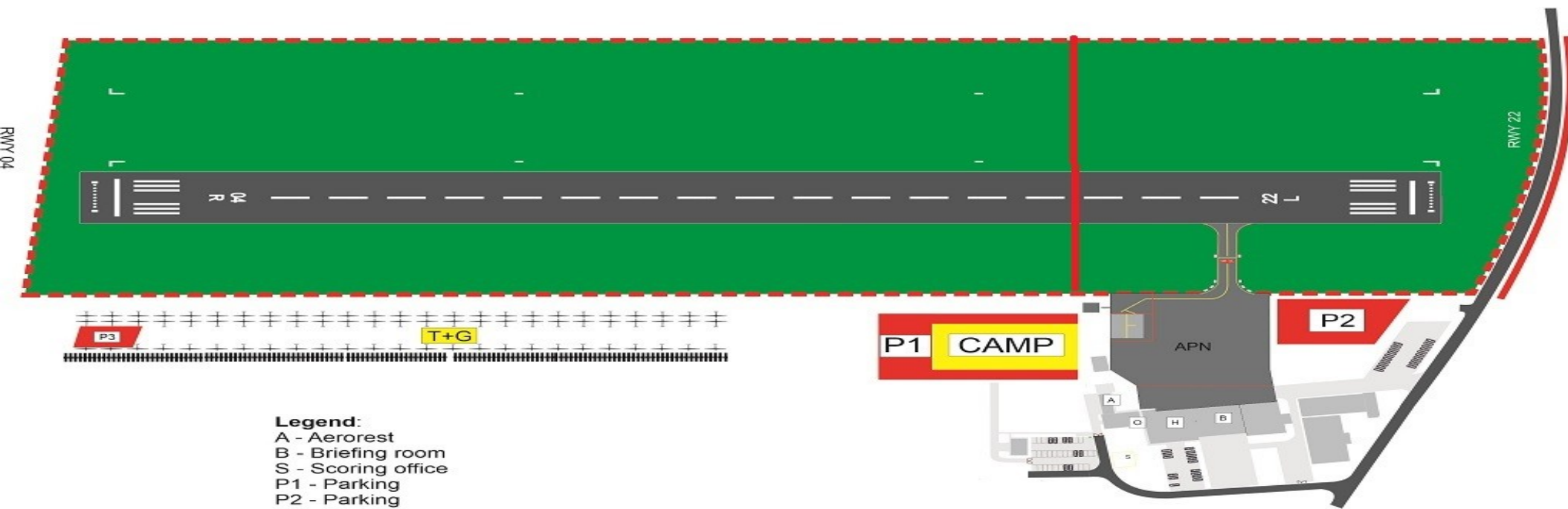

Legend:

- A - Aerorest
- B - Briefing room
- S - Scoring office
- P1 - Parking
- P2 - Parking
- P3 - Parking
- W - Water
- H - Hangar
- TWR - Traffic Tower



Questions





Fly safely!

